

**Traffic Calming** – The combination of mainly physical measures that reduce the negative effects of motor vehicle use, alter driver behavior and improve conditions for non-motorized street users.<sup>1</sup>

## **Introduction:**

Speeding and unsafe driving practices on the neighborhood streets have led to increasing concerns by Sandusky’s residents and city Agencies charged with ensuring traffic safety. Excessive speed and reckless driving jeopardize both the safety and “livability” of our neighborhoods. Therefore, a standard must be set for the proper selection prior to the implementation of any traffic calming device. The purpose of this policy is to provide a methodology for selecting, implementing and designing traffic calming devices used by the City of Sandusky. Until there are federal or state guidelines for the application of these types of devices, this policy shall be used by the City to determine the application of the appropriate traffic calming device.

The decision to use a particular device at a particular location should be made on the basis of an engineering study of the location. Thus, while this policy provides standards for design and application of traffic calming devices, the policy is not a substitute for engineering judgment.

Qualified engineers are needed to exercise the engineering judgment inherent in the selection of traffic calming devices, just as they are needed to locate and design the roads and streets which the devices complement.

This engineering judgment shall be exercised by the Director of Engineering Services and the Traffic Engineer of the City of Sandusky’s Department of Engineering Services.

## **Types and Definitions of Traffic Calming Devices:**

There are currently two (2) acceptable traffic calming devices: Speed Bumps and Speed Humps. Each type of device will be described and defined in this section. In general, bicycles, motorcycles, and other vehicles with rigid or near-rigid suspensions are more susceptible to damage and loss of control from humps or bumps than vehicles with flexible suspensions. However, speed *humps* represent a lesser risk to vehicles with rigid or near rigid suspensions than do speed *bumps*.

**Speed Bumps** – A raised pavement area across a roadway and generally has a height of 3 to 6 inches with a length of 1 to 3 feet. Typically found on private roadways and parking lots and do not tend to exhibit consistent design parameters from one installation to another.

A bump causes significant driver discomfort at typical residential speeds and generally results in vehicles slowing to 5 mph or less at the bump. At high speeds bumps tend to have less overall vehicle impact because the suspension quickly absorbs the impact before the vehicle body can react.<sup>2</sup>

**Speed Humps** – A raised area in the roadway pavement surface extending transversely across the travel way. Sometimes called pavement undulations or

sleeping policemen, speed humps normally have a maximum height of 3 to 4 inches with a travel length of approximately 12 feet.

Within typical residential speed ranges, humps create a gentle vehicle rocking motion that causes some driver discomfort and results in most vehicles slowing to 15 mph or less at each hump and 25 to 30 mph between properly spaced humps in a system. At high speeds the hump can act as a bump and jolt the vehicles suspension and its occupants or cargo.<sup>2</sup>

**Tabletop Type Speed Humps** – This is a variation of the Typical Speed hump with a flat surface at the top. The dimensions are similar to the Typical Speed Hump except that there is a 10 foot long flat surface at the height of the hump (typ. 3”height). This makes the total dimension 22 feet in length instead of 12 feet. This type of install is commonly found at heavily used crosswalks and school zones, where pedestrians require a flat surface to cross the street. This draws attention to the crosswalk because over time, drivers realize that they have to slow down at the crosswalk. Pedestrians have a sense of security knowing that approaching vehicles will slow down.

### **Alternative to Traffic Calming Devices:**

Many cities are simply narrowing roadways (17’-19’ between curbs) in residential areas to deter speeding and reckless driving. This restricts the traffic flow to allow only one lane of traffic to pass if cars are parked on the other. In Sandusky, on street parking is a premium. With nearly half of all housing considered multi-family (rental), there are multiple vehicles for nearly all houses. Driveways cannot accommodate all of these vehicles, and many properties do not even have driveways, making on-street parking a necessity for many of the residential streets. There are pros and cons to this type of action including the restrictions placed on emergency vehicles and snowplows in the narrower streets. This solution is still in the experimental stages in many cities but has seemed to serve its purpose at this stage.

Depending on the results of additional “tests” and “experiments”, a recommendation may be made to the Department of Design & Construction (Project Engineer) to incorporate this approach in our future roadway design.

### **Neighborhood Traffic Calming Implementation Process: How it Works**

Step 1: Project Request from public and/or staff and Preliminary review (does it meet justification & feasibility criteria?) SEE PAGE 4

**Yes**→ Proceed to Step 2

**No**→ Explain in letter form to applicant the reason(s) for denial. Offer alternatives (target enforcement, speed limit signs)

Step 2: A petition is circulated to determine the level of concerns among the residents. (60% required)

**Yes**→ Proceed to Step 3

**No**→ Explain in letter form to applicant the reason(s) for denial. Offer alternatives (target enforcement, speed limit signs)

Step 3: Send letter to explain selection for traffic calming device, if more than speed limit signs, set up a meeting to inform all interested residents of the plans.

Step 4: Trial Installation (if feasible)

For a period of 3 to 6 months.

Step 5: Design and Construction

Step 6: Monitoring

Step 7: Follow-up Evaluation

To be done within 1 to 3 years after construction, staff will conduct a follow-up evaluation to determine if the project goals continue to be met.

## **Traffic Calming Device(s) Justification Criteria**

The following criteria is established to control the installation of traffic calming devices:

Traffic calming devices are suitable in residential areas to manage speed, volume and cut-through traffic. Traffic calming devices shall be installed only in conformance to the design criteria established by the Engineering Department and in effect at the time of their installation.

As with any traffic calming device, additions, alterations or removal of any or all traffic calming devices may occur at any time if conditions warrant.

*Traffic calming devices shall be installed only if ALL of the following justification criteria are met:*

1. Receipt and verification of petitions from (60% minimum of) all residents of the street in question, as defined below; and ,
2. The street in question must have at least 55% of ADT exceeding the posted speed limit\* and ,
3. The street in question must have a speed limit of 25 mph; and,
4. The street in question must be classified as a local or neighborhood collector\*\*, and,
5. The street in question is not a cul-de-sac, and
6. The street in question must not be impaired safety-wise or drainage-wise due to the installation of said traffic calming device, and
7. The street in question must be 750 feet or more in uninterrupted length (excluding intersections), and,
8. The street in question already has posted speed limit signs, and,
9. Alleys and service access roadways will not be considered for traffic calming measures.

\* Traffic Studies (Speed/Volume) will be taken approximately mid-block(s) of the requested zone(s).

\*\* *Local Access Streets* – ADT minimum of 1000 vehicles per day.

*Neighborhood Collector* – Serve a higher function in terms of overall traffic flow, therefore, these roadways require a minimum ADT of 2500 vehicles per day.

If the street meets ALL of the justification criteria above, it will be rated and prioritized according to the following criteria (1. being most important):

### **1. Traffic Volumes**

Volumes will be taken from a Counter for a 24-hour period, averaged over 7 days.

**2. Speed**

Speeds will be taken from a Counter for a 24-hour period, averaged over 7 days.

**3. Accidents**

Accident data considered will be taken from the most recent calendar year (1).

**4. Petitions**

Petitions will be distributed through the “affected area”, which includes the residences/businesses between the proposed humps. This “affected area” will extend to the nearest intersections beyond (outside of) where the humps are proposed to be installed.

**Traffic Calming Device Selection & Placement <sup>4</sup>**

DESIGN SPEEDS OF TRAFFIC CALMING DEVICES	
DEVICE	DESIGN SPEED
Speed Humps (standard profile)	15-20 mph
Table Top Speed Hump	25-30 mph
Narrowing (two-lane)	30-35 mph
Narrowing w/Speed Table	20-25 mph
Narrowing (single-lane angled)	12-15 mph

EFFECTS OF TRAFFIC CALMING DEVICES		
MEASURE	Effects on Volume	Effects on Speed
Diverters/Semi-Diverters	↓ ↓	↓
One-Way Streets	↓ ↓	↑
Speed Humps (standard profile)	↓ ↓	↓ ↓
Table Top Speed Hump	↓	↓ ↓
Narrowings/Throttles	—	↓
↓ ↓ = Large Reduction (>25%) ↓ = Small Reduction	↑ = Small Increase — = No Significant Effect	

Authority of Device Selection & Placement-

The selection of the type of device to be used for traffic calming shall be at the discretion of the engineer (Director of Engineering Services, Project Engineer, or Traffic Engineer) in the exercise of engineering judgment. Input shall be taken from local Emergency Services so as not to interrupt main routes to hospitals and other places of emergency service. Ideal speeds (from the chart above) will be considered heavily in the selection process. The attached drawings govern the design and placement of traffic calming measures and the corresponding signs and pavement markings that must accompany each installation. These drawings are part of the traffic calming policy. Both of these should be placed carefully as to not interrupt any curb cuts (driveways, crosswalk, alleys etc.)

### Speed Humps –

*Definition* – Speed humps are wave-shaped paved humps in the street. The speed hump is parabolic in shape with two approach pads 6 feet in length back-to-back for a total cross-sectional width of 12 feet. The maximum vertical rise is 3 inches +/- .5". Typically, the speed humps are placed in a series rather than singularly.

*General Use* – The use of speed humps is limited to low-volume local streets. Typical street width for local streets is 26' not to exceed 30' in width.

*Positioning* - These are usually placed along streets, typically at a property line along the street. The first speed hump should be located between 250' to 400' from the beginning intersection street curb line. Speed humps should also be spaced between 250' to 300' apart. At least one speed hump shall be placed in each block. The following should also be taken into consideration:

- Located near a street light
- Located near property lines when possible
- Located a minimum of 5-10 feet from driveways
- Not located over manholes or near hydrants
- Not located on sharp horizontal curves
- Not located within 75' of an intersection
- No vegetation to obscure signs

*Table Top Type Speed Humps* – These are also referred to as speed tables, flat-top speed humps, speed platforms, raised crossings or raised crosswalks; sometimes constructed with brick or other textured patterns on the flat section.

*General Use* – The “table top” speed hump is intended for use on local streets with transit routes or neighborhood collectors. Typical street width for this type of table application range from 30' for local streets and up to 36' for neighborhood collectors.

*Positioning* - These are usually placed along streets, typically at a property line along the street. The first speed hump should be located between 250' to 400' from the beginning intersection street curb line. Speed humps should also be spaced between 250' to 300' apart. At least one speed hump should be placed in each block. The following should also be taken into consideration:

- Located near a street light
- Located near property lines when possible
- Located a minimum of 5-10 feet from driveways
- Not located over manholes or near hydrants
- Not located on sharp horizontal curves
- Not located within 75' of an intersection
- No vegetation to obscure signs

*Speed Bumps* – These are typically found on private roadways and parking lots (at parks). The same placement considerations as speed humps should apply to this traffic-calming device also.

**Drawings and Specifications:**  
*Speed Humps*

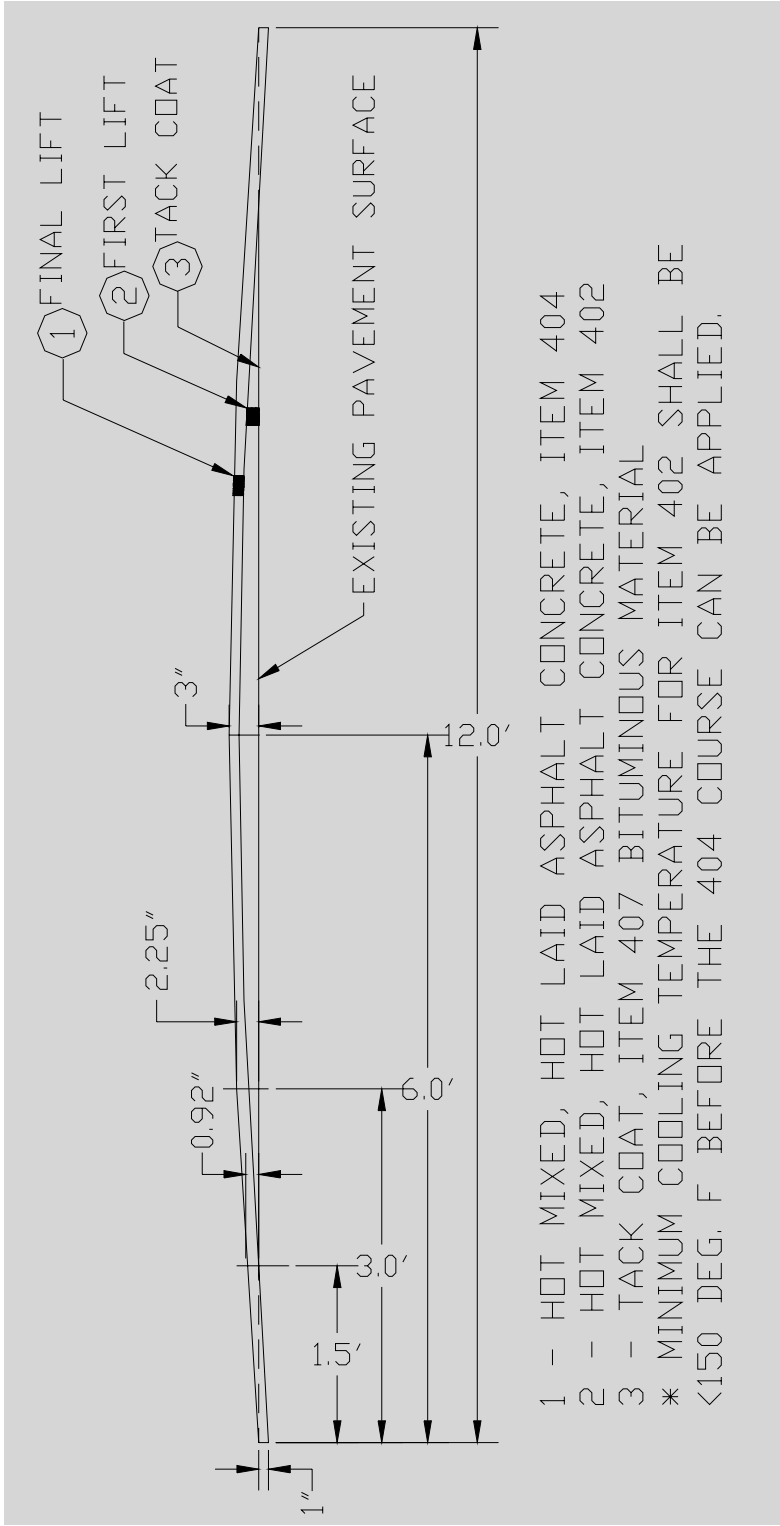

**Drawings and Specifications:**  
*Speed Humps – On Streets with Marked Centerline*

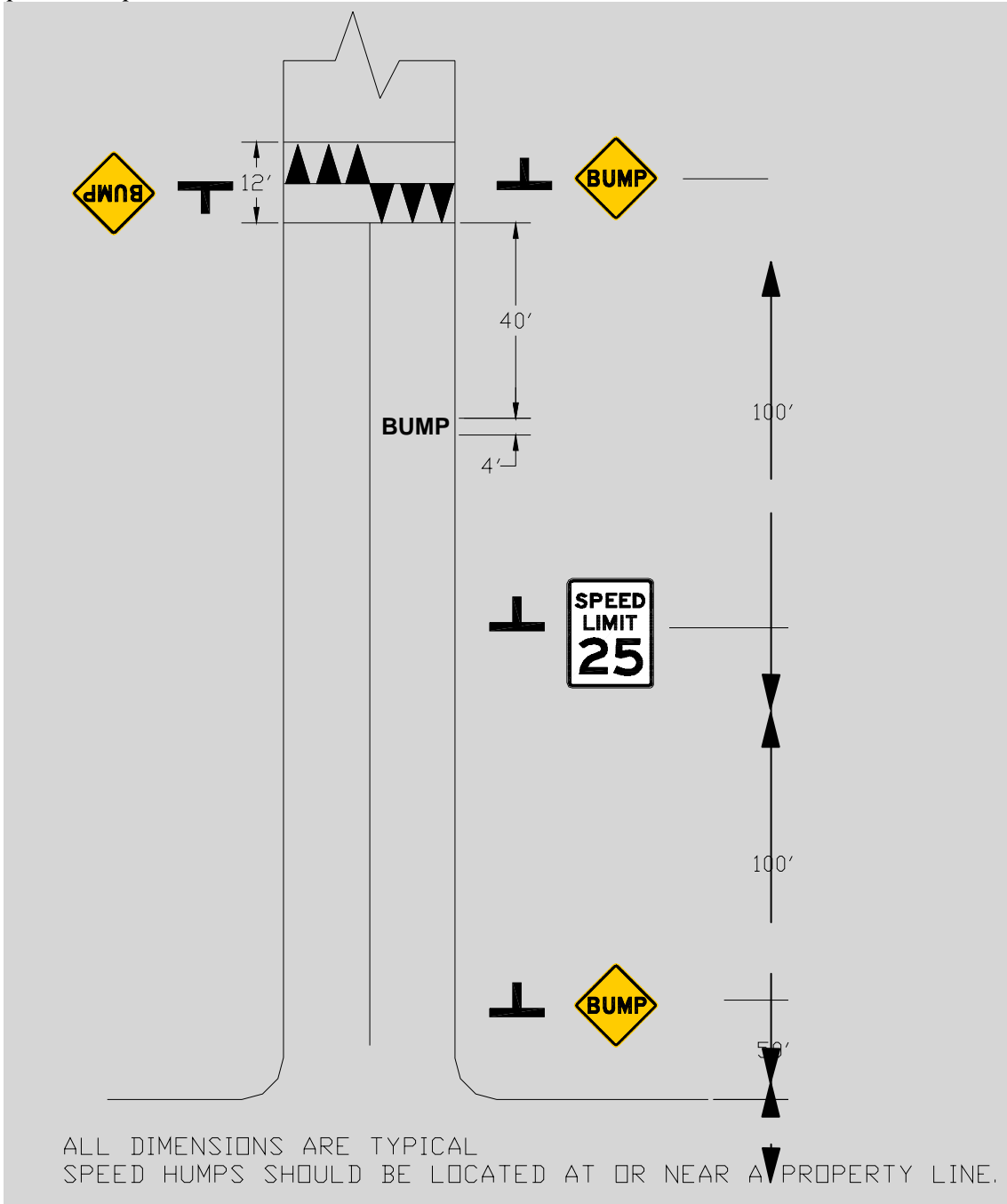

**Drawings and Specifications:**  
*Speed Humps – On Streets without Marked Centerline*

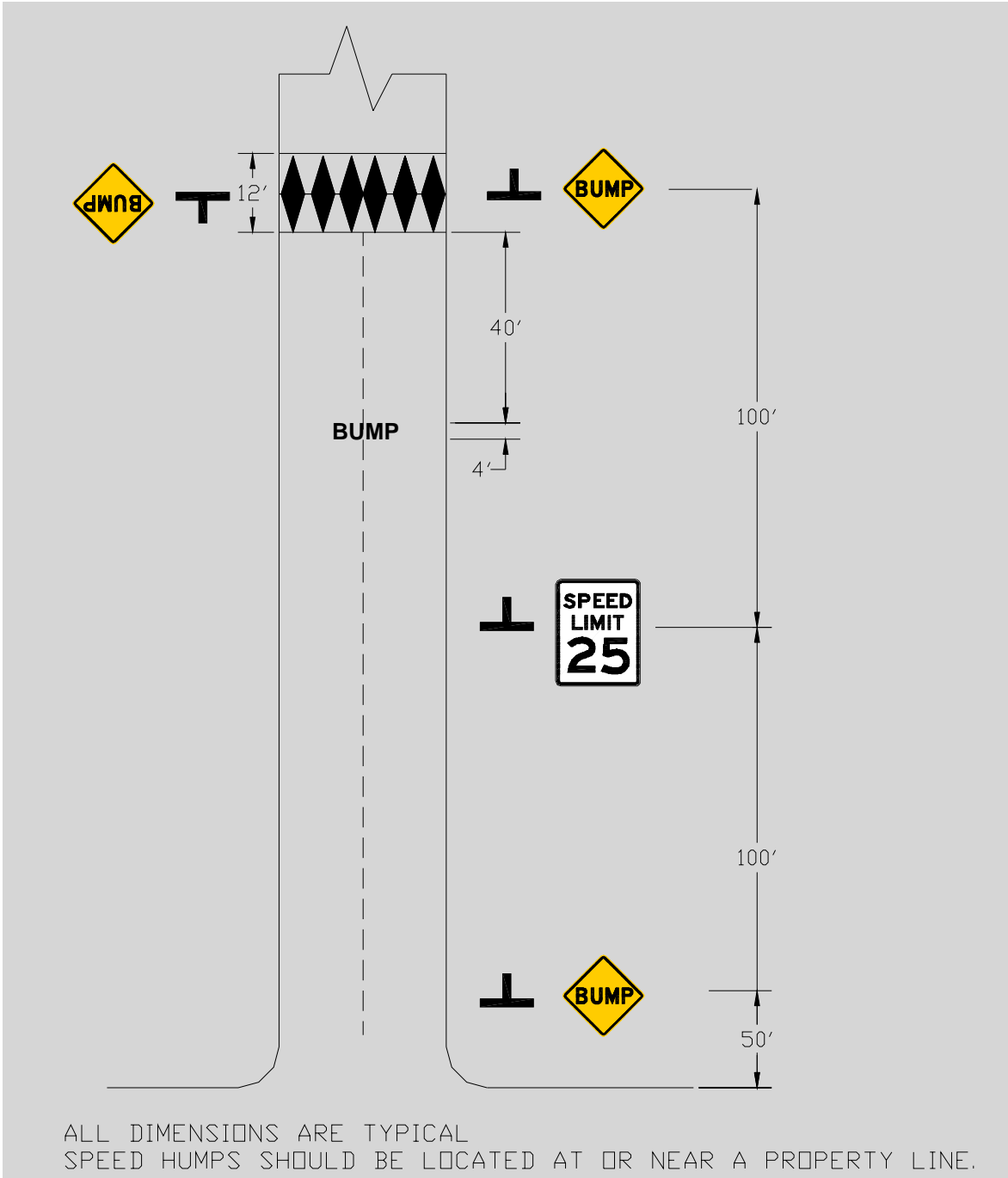

**Drawings and Specifications:**  
*Speed Humps – Shark Teeth (Marking) Detail*

**ON STREETS WITH A  
MARKED CENTERLINE**

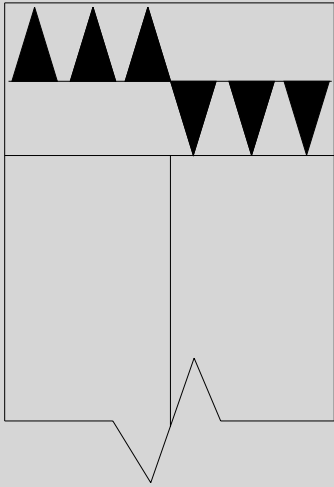

**ON STREETS WITH  
NO CENTERLINE**

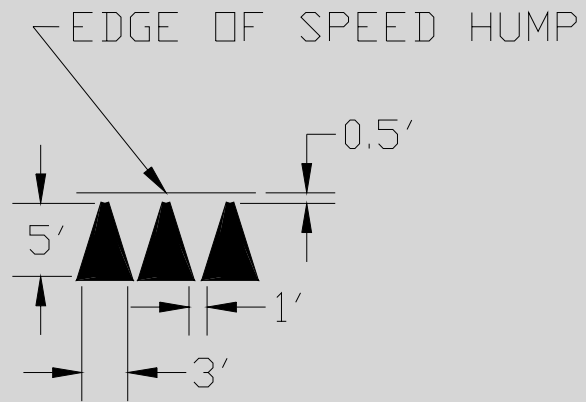
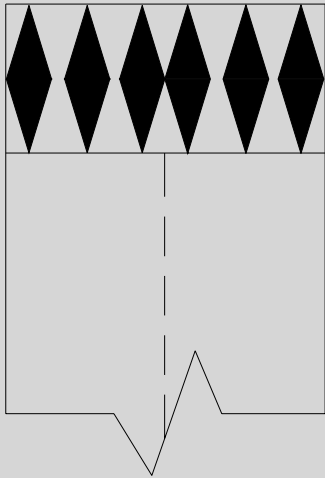

## Drawings and Specifications:

*Table Top-Type Speed Humps – Markings and spacing are similar to regular speed hump*

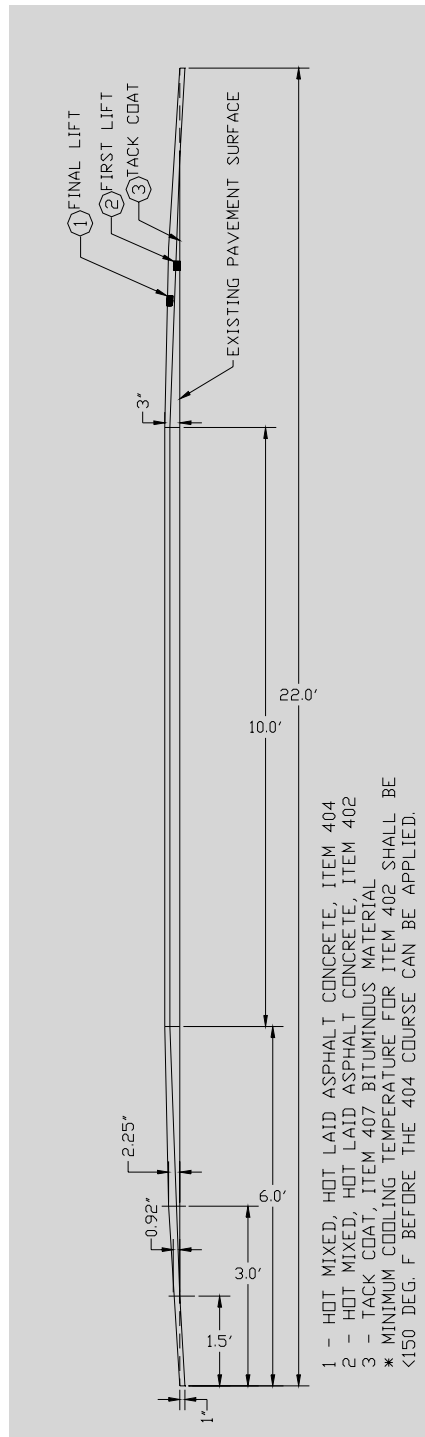

**Funding:**

Following the selection of traffic calming measures the street will be placed on a priority list for funding and installation. Based on the level of funding allocated for this purpose, streets shall be funded beginning with the highest ranked street. If all streets contained on the list cannot be funded during a year, the list will be carried over to the next year.

**Liability:**

The ITE (Institute of Transportation Engineers) states “ Speed humps and other pavement undulations (speed bumps, rumble strips) are *not* traffic control devices as defined by the Manual on Uniform Traffic Control Devices. They are, however, geometric design measures of the roadway and should be designed, installed, operated, and maintained using accepted engineering principles and prudent engineering judgment.”

“If speed humps are not installed in a proper manner and with due care, and property damage or personal injury occurs, it is possible that the installing agency could be found to be maintaining a public nuisance, i.e., a known defect in the street system that might result in increased liability exposure. Therefore, complete and proper documents should be retained to justify the decisions made.”

The same section goes on to read “federal, state, and local laws also should be reviewed to identify any regulations pertaining to roadway design, roadway maintenance, traffic control, or other elements that might be related to the use of speed humps or other geometric design features. Implementation of speed humps should be done in accordance with all federal state and local codes and statutes in regards to design, including Americans with Disabilities Act (ADA) requirements.”<sup>2</sup>

**Disclaimer:**

*Not all types of, or options for traffic calming devices are specified in this policy. However, this does not mean that other alternatives cannot be used. All design, criteria and selection of calming devices shall be based upon engineering judgment.*

**Source Materials:**

1. ITE Journal, July 1997, p.23
2. Guidelines for the Design and Application of Speed Humps, ITE 1997
3. City of Columbus Ohio’s Neighborhood Traffic Management Program
4. R. Ewing, Pedestrian and Transit Friendly Design, Florida Department of Transportation, Tallahassee, Fl. 1996, p. 35.

R. Ewing, Best Development Practices-Doing the Right Thing and Making Money at the Same Time, American Planning Association (in cooperation with the Urban Land Institute, Chicago, IL, 1996, p. 70).